

# Typical Kitchen Ventilation Units

Extraction fan unit complete with  
Pre-Filters and Carbon Filter

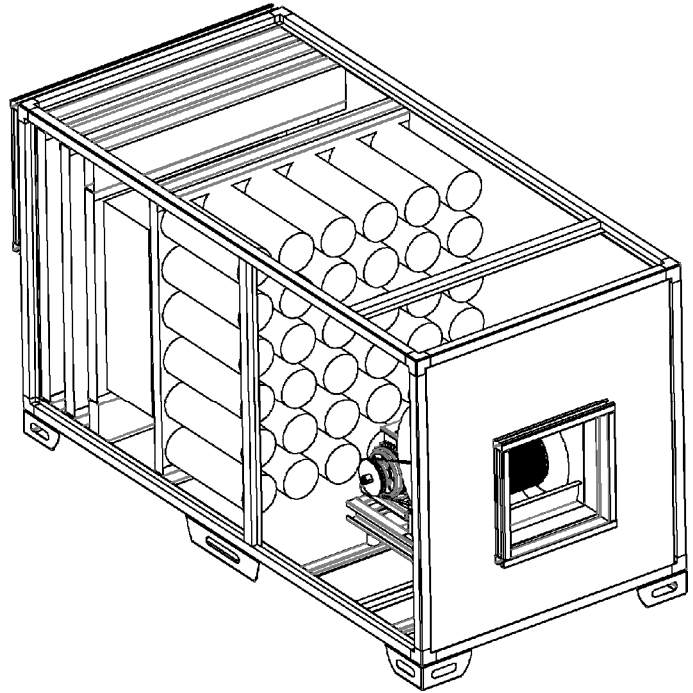

## SIDE VIEW

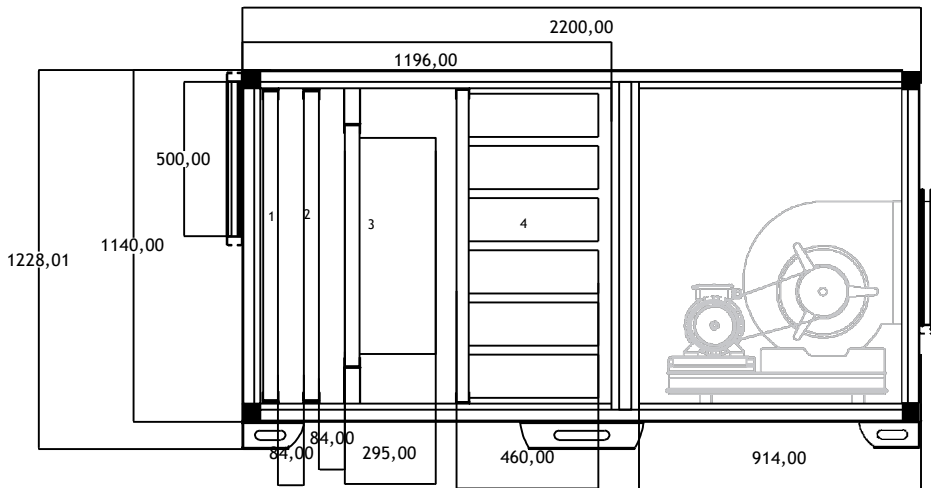

### FILTERS

- 1) G2 METAL OIL FILTER
- 2) G4 FILTER
- 3) F7 RIGIDBAG FILTER
- 4) ACTIVE CARBON CARTRIDGE FILTER

K-KEFAC 450 (4KW-380V)

MOTOR POWER:

4KW

RPM: 1700RPM

VOLTAGE: 380V 50Hz

IMPELLER: RDH 450 NICOTRA

AIR FLOW: 8.500m<sup>3</sup>/h

EX.ST.PRESSURE: 450Pa

INT.PRES. LOSS: 450Pa

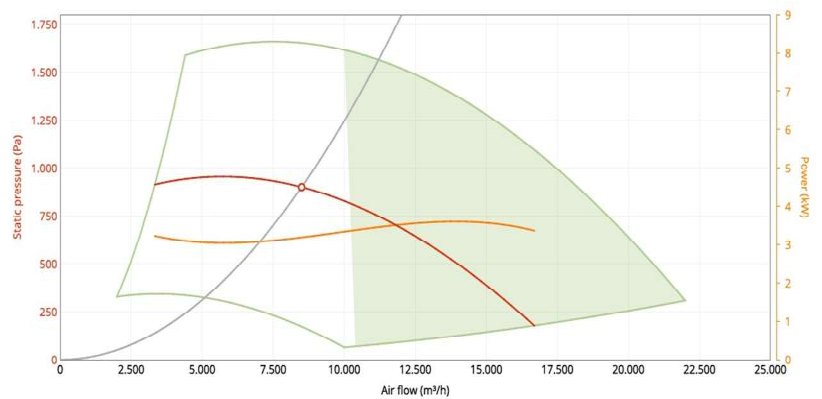

## Full Range of kitchen hoods:

- Wall Mounted
- Island Type
- Extract Only
- Balanced Air Flow

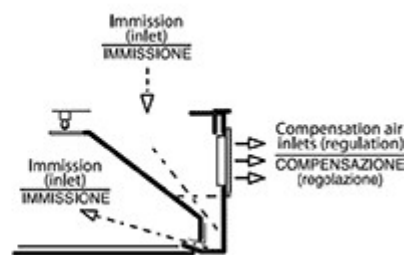
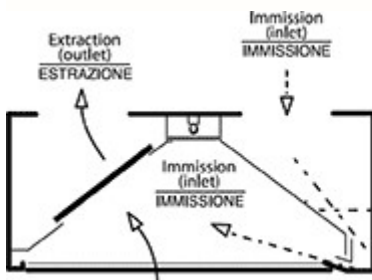

## Variable Speed Controllers in Single Phase and 3 Phase

